



Hitachi Index

Turbo International part number reference	pages 2 - 3
Service kits by model	pages 4 - 7
Journal Bearings	see journal bearing section
Piston Rings	see piston ring section
Gaskets	see gasket section

Hitachi Service Kits by Turbo Model

Turbo model	Kit page no
HT10 & HT12	4-5
HT18-2S	6-7



CROSS REFERENCE - Hitachi to Turbo International

OEM Part No.	Turbo International Part No.	Description	Turbo Model Application
	7-K-1132	SERVICE KIT, MAJOR	HT12
	7-K-1141	SERVICE KIT, MINOR	HT10
	7-K-1195	SERVICE KIT, MINOR	HT12
	7-K-1603	SERVICE KIT, MINOR, DYNAMIC	HT12
	7-K-1604	SERVICE KIT, MINOR, NARROW BEARING	HT10
	7-K-2084	SERVICE KIT, MINOR, DYNAMIC	HT12
	7-K-2966	SERVICE KIT	HT-18S-2S
	7-K-3421	SERVICE KIT, MINOR, DYNAMIC,Nissan P/up application	HT12
	8-K-1001	JOURNAL BEARING STD	HT12
	8-K-1135	THRUST COLLAR	HT12
	8-K-1136	THRUST SPACER	HT12
	8-K-1138	O RING, S/PLATE	HT12
	8-K-1139	RETAINING RING	HT12
	8-K-1140	CARBON SEAL ONLY	HT12
	8-K-1233	PISTON RING C/END STD	HT10
	8-K-1234	JOURNAL BEARING STD	HT10
	8-K-1235	THRUST BEARING	HT10
	8-K-1236	RETAINING RING, J/BRG	HT10
	8-K-1734	JOURNAL BEARING STD/5	HT-10
	8-K-1735	JOURNAL BEARING STD/10	HT-10
	8-K-1736	JOURNAL BEARING 5/STD	HT-10
	8-K-1737	JOURNAL BEARING 5/5	HT-10
	8-K-1738	JOURNAL BEARING 5/10	HT-10
	8-K-1739	JOURNAL BEARING 10/STD	HT-10
	8-K-1740	JOURNAL BEARING 10/5	HT-10
	8-K-1750	JOURNAL BEARING 10/10	HT-10
	8-K-1751	JOURNAL BEARING STD/5	HT-12
	8-K-1752	JOURNAL BEARING STD/10	HT-12
	8-K-1753	JOURNAL BEARING 5/STD	HT-12
	8-K-1754	JOURNAL BEARING 5/5	HT-12
	8-K-1755	JOURNAL BEARING 5/10	HT-12
	8-K-1756	JOURNAL BEARING 10/STD	HT-12
	8-K-1757	JOURNAL BEARING 10/5	HT-12
	8-K-1758	JOURNAL BEARING 10/10	HT-12
	8-K-2033	LOCKNUT, SHAFT, L/HAND THREAD	HT-12
	8-K-2034	SCREW , T/BRG	HT-12
	8-K-2959	JOURNAL BEARING, STD	HT-18S-2S
	8-K-2960	RETAINING RING, J/BRG	HT-18S-2S
	8-K-2961	PISTON RING T/END STD	HT-18S-2S
	8-K-2962	THRUST BEARING	HT-18S-2S
	8-K-2963	BOLT, T/BRG	HT-18S-2S
	8-K-2964	THRUST COLLAR	HT-18S-2S
	8-K-2965	THRUST SPACER	HT-18S-2S
	8-K-2967	JOURNAL BEARING STD/5	HT-18S-2S
	8-K-2968	JOURNAL BEARING STD/10	HT-18S-2S
	8-K-2969	JOURNAL BEARING 5/STD	HT-18S-2S
	8-K-2970	JOURNAL BEARING 5/5	HT-18S-2S
	8-K-2971	JOURNAL BEARING 5/10	HT-18S-2S



CROSS REFERENCE - Hitachi to Turbo International

OEM Part No.	Turbo International Part No.	Description	Turbo Model Application
	8-K-2972	JOURNAL BEARING 10/STD	HT-18S-2S
	8-K-2973	JOURNAL BEARING 10/5	HT-18S-2S
	8-K-2974	JOURNAL BEARING 10/10	HT-18S-2S
	8-K-2975	PISTON RING T/END STD/10	HT-18S-2S
	8-K-2976	PISTON RING T/END STD/20	HT-18S-2S
	8-K-2977	PISTON RING T/END 10/STD	HT-18S-2S
	8-K-2978	PISTON RING T/END 10/10	HT-18S-2S
	8-K-2979	PISTON RING T/END 10/20	HT-18S-2S
	8-K-3152	THRUST BEARING 39.87mm o/d	HT12-18S
	8-K-1003	PISTON RING T/END STD	HT12
	8-K-1134	THRUST BEARING	HT12

HT10
carbon seal

HT12
carbon seal & dynamic seal

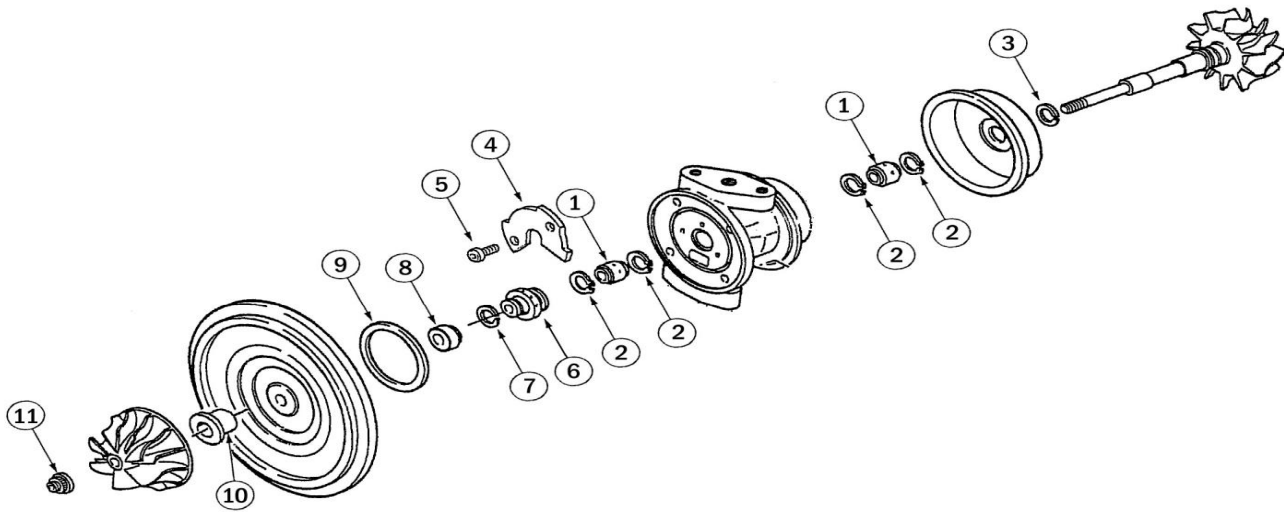



SERVICE KIT - Hitachi

HT10 carbon seal

HT12 carbon seal & dynamic

Item no.	Description	TI Part no.	Qty/ Turbo	TI Kit no.						
				7-K-1141	7-K-1604	7-K-1195	7-K-1132	7-K-1603	7-K-2084	7-K-3421
				<i>Note (i)</i>	<i>Note (ii)</i>	<i>Note (iii)</i>	<i>Note (iii)</i>	<i>Note (ii)</i>	<i>Note (iv)</i>	<i>Note (v)</i>
1	Journal bearing, 0.587" o/d	8-K-1234	2	✓	-	-	-	-	-	-
1	Journal bearing, 0.470" o/d	8-K-1001	2	-	✓	✓	✓	✓	✓	✓
2	Retaining ring, j/brg 0.587"	8-K-1236	4	✓	-	-	-	-	-	-
2	Retaining ring, j/brg 0.470"	8-K-1139	4	-	✓	✓	✓	✓	✓	✓
3	Piston ring, t/end	8-K-1003	1	✓	✓	✓	✓	✓	✓	✓
4	Thrust bearing 45.82mm	8-K-1235	1	-	✓	-	-	-	-	-
4	Thrust bearing 45.82mm	8-K-1134	1	✓	-	✓	✓	✓	✓	-
4	Thrust bearing 39.87mm (v)	8-K-3152	1	-	-	-	-	-	-	✓
5	Bolt, thrust bearing	8-K-2034	4	✓	✓	✓	✓	✓	✓	✓
6	Thrust collar, c/seal	8-K-1135	1	-	-	-	✓	-	-	-
7	Piston ring, c/end	8-K-1233	1	✓	✓	-	-	-	✓	✓
8	Carbon seal, encapsulatec	8-K-1140	1	-	-	✓	✓	-	-	-
9	O ring, brg/hsg	8-K-1138	1	✓	✓	✓	✓	✓	✓	✓
10	Thrust spacer, c/seal	8-K-1136	1	-	-	-	✓	-	-	-
11	Locknut, t/shaft	8-K-2033	1	✓	✓	✓	✓	✓	✓	✓

Note (i) HT10 carbon seal with 0.587"/14.90mm o/d

(ii) HT12 carbon seal with 0.469"/11.93mm o/d

(iii) HT12 carbon seal with 0.469"/11.93mm o/d Mazda RX7 twin turbo application

(iv) HT12 dynamic seal with 0.469"/11.93mm o/d

(v) HT12 thrust bearing Nissan Pick-up application

See JOURNAL BEARING section for oversize & under-size parts - page 69 - 70

See PISTON RING section for oversize parts - page 72

See GASKET section

HT18-2S

carbon seal

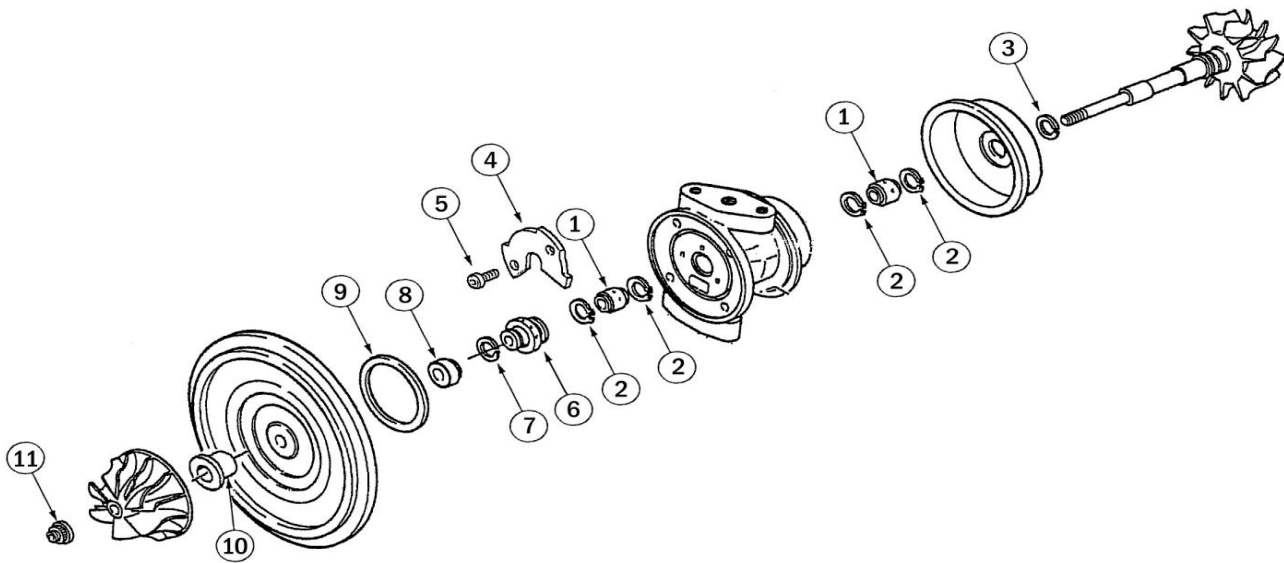



SERVICE KIT - Hitachi

HT18-2S

Item no.	Description	TI Part no.	Qty/ Turbo	TI Kit no. 7-K-2966
1	Journal bearing	8-K-2959	2	✓
2	Retaining ring, j/brg.	8-K-2960	4	✓
3	Piston ring, t/end	8-K-2961	1	✓
4	Thrust bearing	8-K-2962	1	✓
5	Bolt, thrust bearing	8-K-2963	4	✓
6	Thrust collar	8-K-2964	1	✓
7	Thrust spacer	8-K-2965	1	✓
8	Carbon seal, encapsulated		1	-
9	O ring, brg/hsg		1	-
10	Thrust spacer, c/seal		1	-
11	Locknut, t/shaft		1	-

To achieve the correct stacked tolerance, **all** the above parts must be used in rebuilding.

See JOURNAL BEARING section for oversize & under-size parts - page 70

See PISTON RING section for oversize parts - page 72

See GASKET section



This page has been intentionally left blank